

Load Balancing in Ad Hoc Networks: Single-path Routing vs. Multi-path Routing

Yashar Ganjali, Abtin Keshavarzian
Department of Electrical Engineering
Stanford University
Stanford, CA 94305
Email: {yganjali, abtink}@stanford.edu

Abstract—Multi-path routing has been studied thoroughly in the context of wired networks. It has been shown that using multiple paths to route messages between any source-destination pair of nodes (instead of using a single path) balances the load more evenly throughout the network. The common belief is that the same is true for ad hoc networks, *i.e.*, multi-path routing balances the load significantly better than single-path routing. In this paper, we show that this is not the case. We introduce a new model for evaluating the load balance under multi-path routing. Using this model, we show that unless we use a very large number of paths (which is very costly and therefore infeasible) the load distribution is almost the same as single-path routing. This is in contrary to the previous existing results which assume that multi-path routing distributes the load uniformly.

I. INTRODUCTION

Providing multiple routing paths between any source-destination pair of nodes has been proved to be very useful in the context of wired networks [1], [4], [7], [8]. The general understanding is that dividing the flow among a number of paths (instead of using a single path) results in a better balancing of load throughout the network [1], [8].

In the context of mobile ad hoc networks, several multi-path routing protocols have been proposed [2], [10]. The performance of these protocols has been mainly studied through simulations. Recently, some papers have studied different aspects of multi-path routing by providing analytical models [3], [9]. The only known result which studies the distribution of load in an ad hoc network is due to Pham and Perreau [6]. They have introduced an analytic model for evaluating the load balance in an ad hoc network under single-path routing. For multi-path routing, they assume that the load is uniformly distributed throughout the paper, regardless of the number of paths used.

In this paper, we propose a new analytic model for evaluating the load balance in an ad hoc network. Our model shows that despite what is widely believed in the research community, multi-path routing does not necessarily result in a better load balance compared to single-path routing. In fact, we have shown that in any ad hoc network with a huge number of nodes multi-path routing can balance the load better than single-path routing only if we use a very large number of paths (*i.e.*, a large fraction of the total number of nodes in the network) between any source-destination pair of nodes. Since the discovery (and maintenance) of such a large number of paths is very costly, building such a system seems to be infeasible. Therefore, we conclude that simply using multiple shortest path routes instead of a single-path does not improve the load balance.

The rest of this paper is organized as follows: Section II introduces the network and traffic model. In Section III a brief overview of existing models for evaluating the load balance under single-path and multi-path routing is given. Then, in Section IV we introduce a new analytic model for measuring the load distribution under multi-path routing in an ad hoc network. Section V presents some simulation results which justify our model. Finally, Section VI concludes this paper.

II. PRELIMINARIES

A. Network and Traffic Model

We assume that our network consists of a large number of mobile nodes which are uniformly distributed inside a circle of radius R . The density of nodes inside this circle is denoted by δ . We also assume that each mobile node in the network can directly communicate with any other node within a distance of at most T , a pre-specified threshold. Although, this is not an essential assumption as we will see later (Section IV-D). For simplicity, we

will assume that there is a link between any two nodes which can communicate directly.

Each node sends messages to any other node with a uniform rate λ . In single-path routing, each source node sends its messages via the shortest path to its corresponding destination. In multi-path routing, each source node finds the first K shortest paths to its destination and divides its load evenly among these paths. Usually these paths are node-disjoint, but as we will see in Section IV-D, our analysis can easily be extended to the case where they are only edge-disjoint (and can share nodes).

B. Comparison of Single-path and Multi-path Routing

There are several criteria for comparing single-path routing and multi-path routing in ad hoc networks. First, the overhead of route discovery in multi-path routing is much more than that of single-path routing. On the other hand, the frequency of route discovery is much less in a network which uses multi-path routing, since the system can still operate even if one or a few of the multiple paths between a source and a destination fail. Second, it is commonly believed that using multi-path routing results in a higher throughput. The reason is that all nodes are assumed to have a fixed (and limited) capacity (bandwidth and processing power). Since multi-path routing distributes the load better, the overall throughput would be higher.

In the following sections we show that this is not true by evaluating the load distribution in an ad hoc network. Our analysis shows that increasing the number of routing paths per source-destination pair of nodes does not significantly change the load balance. It means there is not a major gain in throughput as well.

III. LOAD DISTRIBUTION ANALYSIS

The network and traffic model introduced in Section II-A are symmetric in the sense that all nodes of the same distance r from the center of the network are similar. In other words, the amount of load going through all nodes, which are of a fixed distance r from the center, is the same.

Pham and Perreau [6] have introduced a simple model for determining the load distribution on an ad hoc network which uses single-path routing. Their analysis shows that the maximum load is observed in the center of the network and therefore if all nodes are of the same capacity (processing and bandwidth) the nodes in the center form the bottleneck that affect the throughput of the whole system. Studying this model is very useful for understanding the new model we introduce. Therefore, we will briefly sketch it in the following section.

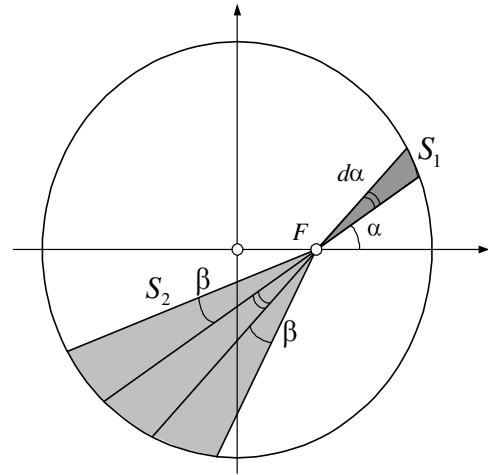

Fig. 1. Pham and Perreau's method.

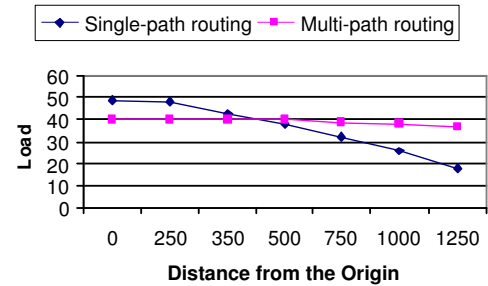

Fig. 2. Pham and Perreau's result [6].

A. Single-path Routing

Let us consider a fixed node F at distance r from the center of the network (circle) and a line L going through F such that the angle between L and the x -axis is α . As shown in Figure 1 we also consider a small portion of the disk centered around the line L with aperture $d\alpha$ and call it S_1 .

The goal is to determine the amount of traffic originated by any source node in region S_1 that goes through node F . Pham and Perreau have made the observation that because of the high density of nodes the shortest path is very close to the line segment connecting any source-destination pair. Thus, any packet originated at a node A in part S_1 of the network and destined to any node B in part S_2 (the portion of disk around L opposite to S_1 and with aperture β) will go through the node F . The constant β is a small positive real number, independent of α and $d\alpha$ which depends on several parameters like the density of nodes and the topology of the network.

Based on this observation the amount of traffic originated at any node in region S_1 and going through the node F is proportional to the area of S_1 times the area

of S_2 . Summing over different values of α one can determine the total amount of flow going through node F . Figure 2 their result. This result is consistent with the simulations which we have done (as we will see in Section V).

B. Multi-path Routing

To the best of our knowledge, there is no realistic model for finding the load distribution under multi-path routing in ad hoc networks. The best result assumes that the load is distributed uniformly throughout network [6], *i.e.*, the load on each node of the network is the same (see Figure 2). This model does not take into account neither the number of paths used in multi-path routing nor the distance of nodes from the center of the circle. We believe these parameters highly affect the load of each node and will introduce a new model for finding the load distribution in the following section.

IV. LOAD DISTRIBUTION UNDER MULTI-PATH ROUTING

As mentioned in the previous section, two main parameters that can affect the load on the nodes when multi-path routing is employed, are: (1) the number of paths (and actually the method used to find the paths); and (2) the distance of the node from the center. In this section, we first describe a new model for multi-path routing and then use it to analytically compute the traffic load on the nodes. We believe our model and the method used for load computation is more general than the previous model.

A. The Rectangle Model

Consider nodes A and B in the network. If the network is dense, the shortest path between these two nodes will be very close to the line segment AB . Under multi-path routing, the first K shortest paths will be used. We can expect that these paths form K parallel lines from A to B . To see this effect we run some simulations. Figure 3 shows the results. As it can be seen, the set of nodes used in these paths approximately from a rectangle. This assumption is more accurate for a dense network. The length of this rectangle is the same as distance between A and B . However, its width mainly depends on number of paths, and node density. We denote the width by $2W$, and assume that it is independent of the position of nodes A and B . In Section IV-D, the selection of this parameter is discussed in more details.

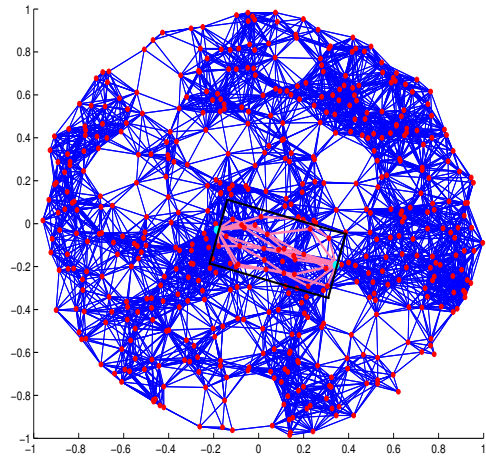

Fig. 3. The rectangle model.

B. Locus Problem

Consider two fixed points A and F , we want to find the set of all points B such that point F is inside the rectangle created by points A and B as described above. This set of points corresponds to the nodes that under multi-path policy, part of their traffic that they send to node A , passes through node F . We need to consider two separate cases. Let d_{AF} denote the distance between points A and F .

1) *First Case:* $d_{AF} > W$: All points B should satisfy two conditions. Distance from point F to the line segment AB should be less than W and the projection of point F on line AB should lie between A and B . These two conditions leads to the following two constraints:

- 1) Consider a circle with radius W and center F , then draw the two tangent lines from point A to this circle. These two lines form the region which is shown in Figure 4. All points B should lie inside this region.

To show that this is a necessary condition, consider a point B outside this region. Clearly the distance from point F to the line AB will be larger than W and therefore point F can not be inside the rectangle formed by point A and B .

- 2) Consider a circle with line segment AF as its diameter. All points B should be outside this circle. They should also be inside the half space created by the line normal to AF . This region is shown in Figure 5.

Consider an arbitrary point B and let C denote the point where line AB intersects with the circle. The angle \hat{ACF} is 90 degrees (since AF is the diameter), so C is the projection of F on line AB .

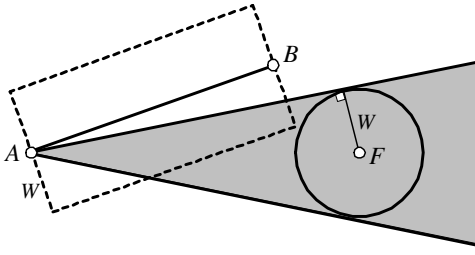

Fig. 4. Region 1.

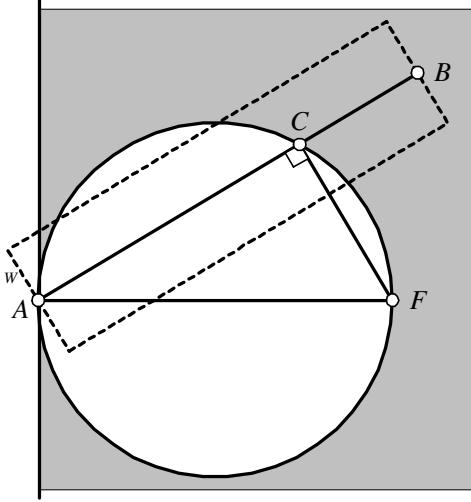

Fig. 5. Region 2.

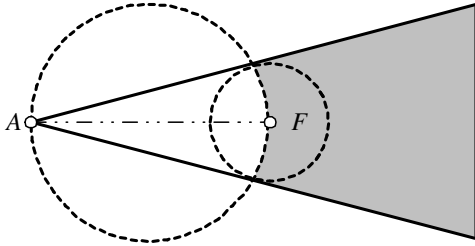

Fig. 6. Locus of all points B for first case.

If B is outside the circle, then C lies between A and B .

Combining the above two regions, we find the locus of all points B which is shown in Figure 6.

2) *Second Case: $d_{AF} \leq W$:* When d_{AF} is less than W , point A will lie inside the circle with center F and radius W , so we can not draw the tangent lines. It is easy to see that, in this case, the locus of points B is same as region two shown in Figure 5. It is formed by excluding all points inside the circle with diameter AF from the half space created by a line perpendicular to line AF .

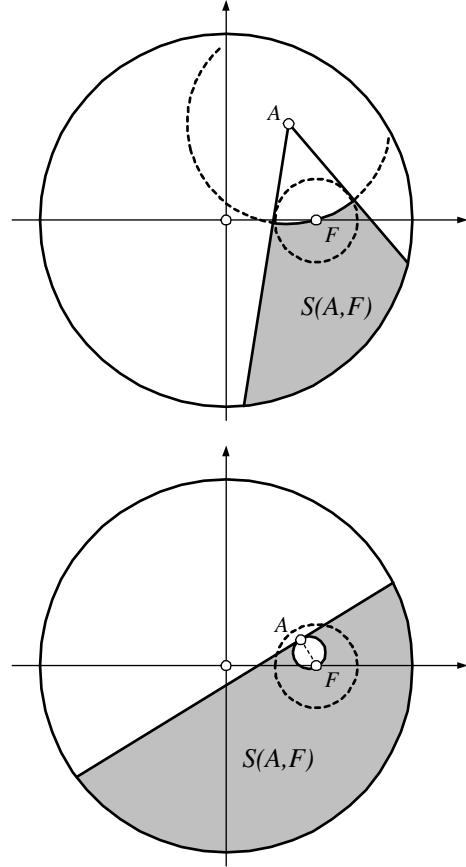

Fig. 7. Definition of $S(A, F)$.

C. Definition of $S(A, F)$ and Traffic Load Computation

Consider two fixed points A and F which are now restricted to be inside a circle with radius R . Then find the locus of points B as described in previous section and intersect it with the circle. Two examples corresponding to the two different cases described in the previous section, are shown in Figure 7. Later, we use the area of this region to compute the traffic load on different nodes. We denote this area by $S(A, F)$. Note that $S(A, F)$ depends on position of point A and F and parameter W . This function can be computed using analytical methods. Unfortunately the resulting answer has a very complex closed form expression. In Appendix we describe an algorithmic method to compute this area. If we multiply this area by the density of nodes (δ), we get the number of nodes that have the property that part of their flow to a node at point A , will pass through a node at point F . Thus, to compute the total traffic passing through node F , we need to consider all different positions of point A and sum up $\delta S(A, F)$ computed for each position of

point A . Mathematically it can be written as follows:

$$\text{Traffic} = \frac{\lambda}{K} \int_0^R \int_0^\pi \delta S(A, F) \delta r_A d\phi_A dr_A, \quad (1)$$

where (r_A, ϕ_A) shows the position of point A in polar system. Recall that λ represents the amount of traffic generated by each flow. Observe that since K paths are used to transmit each flow, in the above equation, λ is first normalized by K . We use numerical methods to compute the above expression.

D. How to choose W ?

As mentioned before W is a very important parameter. Clearly this parameter depends on the method used to find paths. First we consider the case where only the shortest path between the nodes is computed, and we find an approximate expression for W , then we generalize it to the case of multiple paths.

Since it is assumed that the nodes are distributed uniformly and their positions are independent of each other, the number of nodes in a fixed region with area A will have a Poisson distribution [5] with mean δA :

$$\mathbb{P}(\text{number nodes in area } A = k) = e^{-\delta A} \frac{(\delta A)^k}{k!}. \quad (2)$$

Consider two points A and B such that their distance is $T + \epsilon$ where ϵ is very small positive number. Recall that T denotes the transmission range of each node. Consider the rectangle over points A and B with width $2W$. If the shortest path lies within this rectangle, then we need to have at least one point in it. The average number of points in the rectangle is $2\delta WT$. If this average is in the order of 10, (e.g., we choose 5) then the probability of not getting any node will be very small:

$$\mathbb{P}(\text{No node}) = e^{-2\delta WT} (= e^{-5} = 0.0067), \quad (3)$$

and therefore W should be:

$$W = \frac{O(1)}{\delta T}. \quad (4)$$

This shows that W is inversely proportional to density of nodes (δ) and the range (T). If for the single shortest path, $W_1 = W$ is chosen, we assume that for multi-path case when K shortest paths are used, $W_K \approx KW$. This assumption was justified by simulation results.

The value of W also depends on the path discovery algorithm. For example, in case of node-disjoint paths, simulations shows that W is typically larger than the case where link-disjoint paths were used. However, the assumptions that W linearly scales with the number of paths and is independent of the distance between two points, are valid for different rout discovery methods.

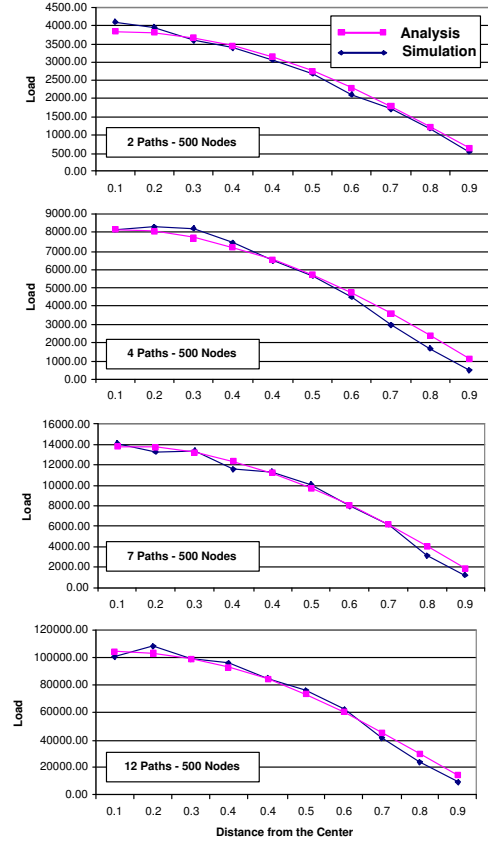

Fig. 8. Simulation results.

V. SIMULATIONS AND RESULTS

In this section, we will first justify our model using simulations. Then we will argue that multi-path routing does not improve the load balance in the network.

Figure 8 shows the result from both simulation and our analysis. The radius of the network is set to $R = 1$, and $N = 500$ nodes are thrown randomly inside the unit circle. The graphs show the load on nodes versus their distance from the center. The parameter W is selected in a way that the result from the analysis matches the simulation result for the case of single path. Then scaled values of obtained W are used to find analytical results for $K=2,4,7$, and 12 paths. This figure not only demonstrates that our model and analysis methods are correct, but it also proves the validity of the assumption that W scales linearly with the number of paths.

Figure 9 shows the normalized load versus distance from center of network for different number of paths. The curves are obtained by analytical method described in previous section. As expected, the nodes in the center of the network are the most heavily loaded ones. Observe that for small number of paths, the traffic load is almost

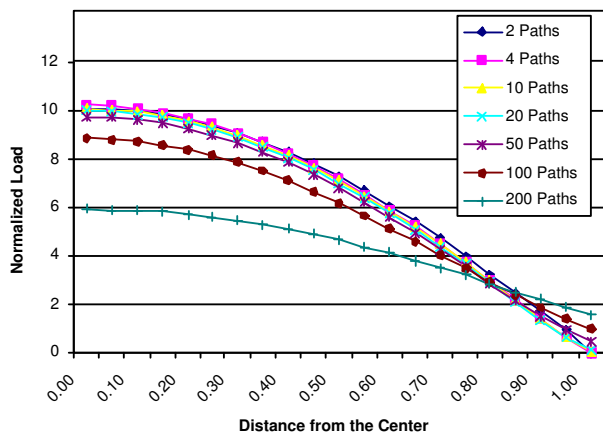

Fig. 9. Load versus distance from center.

the same as the case for the single path. This remains true for even 20 paths. After that, for number of paths larger than 20, we start to see the effect of using multi-paths effect, and the load is more balanced over the network. However, to get a significant change in the curves and a more balanced network, one has to use more than 100 paths which is not practical due to the overhead it has to maintain this many paths per flow.

VI. CONCLUSION

We have studied the effect of multi-path routing in balancing the load in an ad hoc network. Despite what is commonly believed in the networking community, using multiple paths for routing messages does not necessarily balance the load better than single-path routing. We have shown that unless we use a huge number of paths multi-path routing does not improve the load balance. The reason is the fact that in an ad hoc network with a high density of nodes shortest paths connecting any pair of nodes tend to be very close to the line segment connecting those two nodes. This is still true even if we use a small number of paths. Therefore, multi-path routing behaves very similar to single-path routing in this case. To overcome this problem one has to find routing paths such that they push the traffic further from the center of the network. The details of how this can be done is a very interesting open problem in its own turn.

ACKNOWLEDGMENTS

The authors would like to thank Prof. Nick McKeown, Prof. Balaji Prabhakar, and Alireza Khalili for valuable input and discussion.

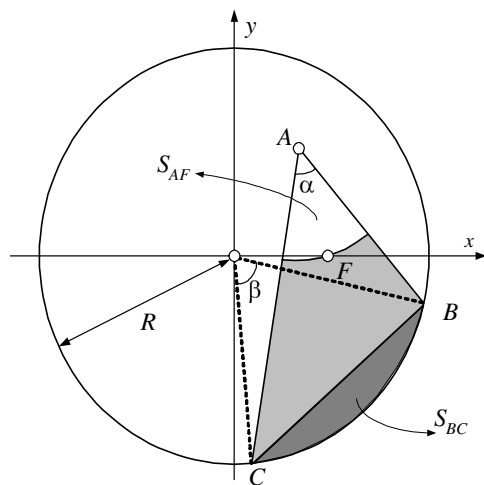

Fig. 10. Computation of $S(A, F)$.

REFERENCES

- [1] R. Krishan and J.A. Silvester. Choice of allocation granularity in multi-path source routing schemes. In *IEEE INFOCOM'99*, volume 1, pages 322–329, IEEE, 1993.
- [2] S.J. Lee and M. Gerla. AODV-BR: Backup routing in ad hoc network. In *IEEE WCNC'00*, pages 1311–1316, IEEE, 2000.
- [3] A. Nasipuri and S.R. Das. On-demand multi-path routing for mobile ad hoc networks. In *IEEE ICCCN'99*, pages 64–70, IEEE, 1999.
- [4] R.C. Ogier and V. Ruthenburg. Minimum-expected-delay alternate routing. In *IEEE INFOCOM'92*, pages 617–625, Florence, Italy, IEEE, 1992.
- [5] A. Papoulis. Probability and Statistics. *Prentice Hall*, 1st edition, 1990.
- [6] P.P. Pham and Sylvie Perreau. Performance analysis of reactive shortest path and multi-path routing mechanism with load balance. In *IEEE INFOCOM'03*, pages ..., San Francisco, CA, USA, IEEE, 2003.
- [7] N.S.V. Rao and S.G. Batsell. QoS routing via multiple paths using bandwidth reservation. In *IEEE INFOCOM'98*, volume 1, pages 11–18. IEEE, 1998.
- [8] R. Rom, I. Cidon, and Y. Shavitt. Analysis of multi-path routing. *IEEE/ACM Transactions on Networking*, 7(6):885–896, 1999.
- [9] A. Tsirigos and Z.J. Haas. Multi-path routing in the presence of frequent topological changes. *IEEE Communications Magazine*, November 2001.
- [10] L. Wang *et al.* Multi-path source routing in wireless ad hoc networks. In *Canadian Conf. Elec. Comp. Eng.*, volume 1, pages 479–483, 2000.

APPENDIX

In this section we describe an algorithmic method for computation of $S(A, F)$. Assume that A and F are respectively located at (x_A, y_A) and (x_F, y_F) . Then:

$$d_{AF} = \sqrt{(x_A - x_F)^2 + (y_A - y_F)^2}. \quad (5)$$

First consider the case in which $W \leq d_{AF}$. The angle $\alpha = \widehat{BAC}$ shown in figure 10 is given by:

$$\alpha = 2 \sin^{-1} \left(\frac{W}{d_{AF}} \right). \quad (6)$$

and the slope of line AF is:

$$m_{AF} = \frac{y_A - y_F}{x_A - x_F}. \quad (7)$$

We need to compute the coordinates of points B and C . Note that the slope of AB and AC can be obtained from:

$$m_{AB} = \frac{m_{AF} + \tan \left(\frac{\alpha}{2} \right)}{1 - m_{AF} \tan \left(\frac{\alpha}{2} \right)}, \quad (8)$$

$$m_{AC} = \frac{m_{AF} - \tan \left(\frac{\alpha}{2} \right)}{1 + m_{AF} \tan \left(\frac{\alpha}{2} \right)}. \quad (9)$$

The coordinates of point B are given by:

$$\Delta_B = (1 + m_{AB}^2) R^2 - (m_{AB}x_A - y_A)^2, \quad (10)$$

$$x_B = \frac{(m_{AB}^2 x_A - m_{AB} y_A) \pm \sqrt{\Delta_B}}{1 + m_{AB}^2}, \quad (11)$$

$$y_B = m_{AB}(x_B - x_A) + y_A. \quad (12)$$

The same set of equations can be used to compute the coordinates of point C . Note that in (11) the plus or minus sign are used depending on the position of point A and F . We should make sure that the correct sign is used.

Since the position of the three points A, B , and C are known, we can compute the area of triangle ABC :

$$S_{ABC} = \frac{1}{2} [x_A(y_B - y_C) - x_B(y_A - y_C) \quad (13)$$

$$+ x_C(y_A - y_B)]. \quad (14)$$

To compute $S(A, F)$ we also need the area of the region shown in figure as S_{BC} . To find that we need $\beta = \widehat{BOC}$:

$$\beta = 2 \sin^{-1} \left(\frac{d_{BC}}{2R} \right). \quad (15)$$

Then S_{BC} is:

$$S_{BC} = \frac{R^2}{2} (\beta - \sin(\beta)). \quad (16)$$

The only other parameter needed is the area S_{AF} :

$$S_{AF} = \left(\frac{d_{AF}}{2} \right)^2 (\alpha + \sin \alpha). \quad (17)$$

Combining all these results we obtain:

$$S(A, F) = S_{ABC} + S_{BC} - S_{AF}. \quad (18)$$

For the case $d_{AF} < W$, we can just set $\alpha = \pi$. Note that S_{ABC} will be zero in this case.